



valid from 23.07.23

6. Range of Articles

6.1 P - platforms

- standard execution
- special execution
- special shape triangle
- special shape circle
- special shape trapezoid
- special surface
- extras

6.2 U - base construction

- fix LV
- levelling VS
- telescopic TF
- stepless adjustable LS in combination with nivtec LV leg
- alu diagonal bracing (variant 1 - variant 4)
- alu horizontal bracing
- theatre tier height 16,66 cm (fix LV / levelling VS)
- inclinable KG
- movable: wheels + extension adapters
- for scaffolding: weight girder

6.3 Z - accessories

- stairway & gallery
- stage & gallery
- ramp
- other

6.4 G - rails

- stage
- stage & gallery
- stairway: tier height 20 cm
- stairway: tier height 16,66 cm
- special rails & more
- railing accessories
- connection of ascents and descents with stage

6.5 T - transport

- safety
- transport wheels
- transport trolleys

6.6 E - spare parts

- platform
- base construction
- stairway
- rail
- accessories & more

standard execution

rectangular

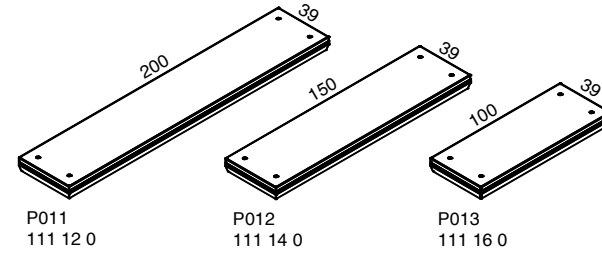
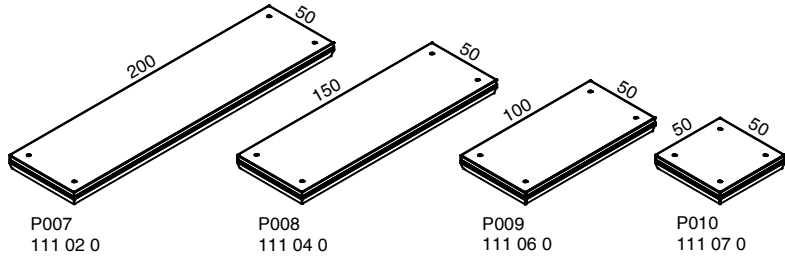
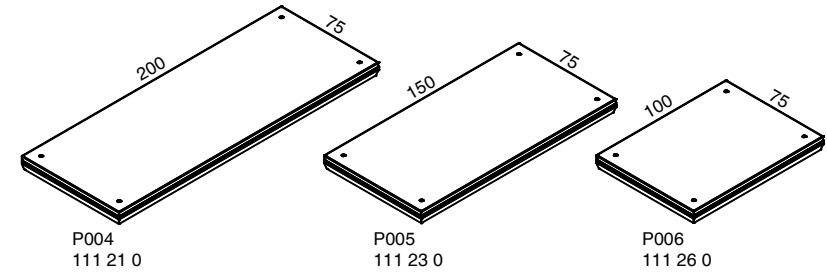
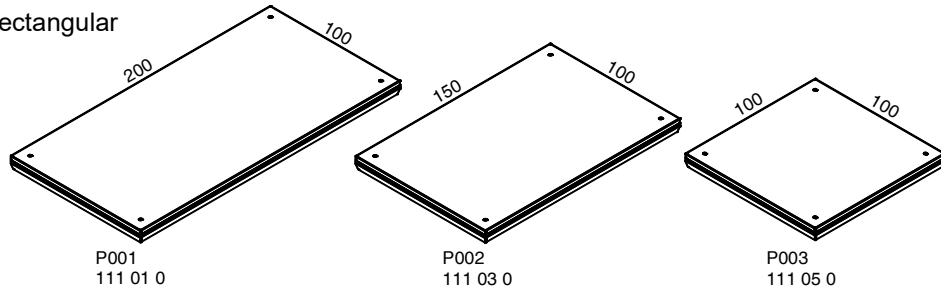

special execution

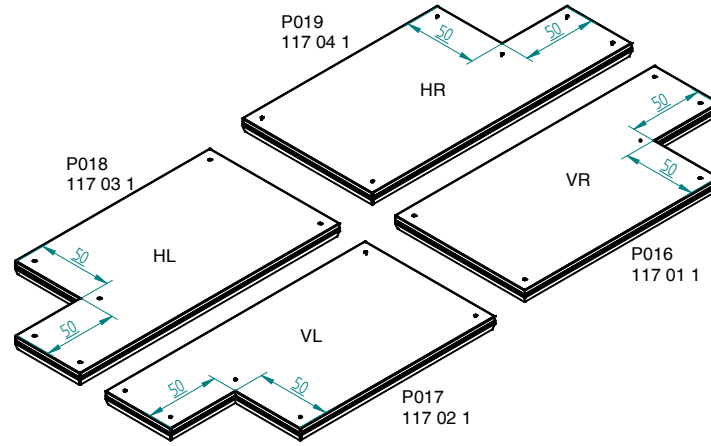
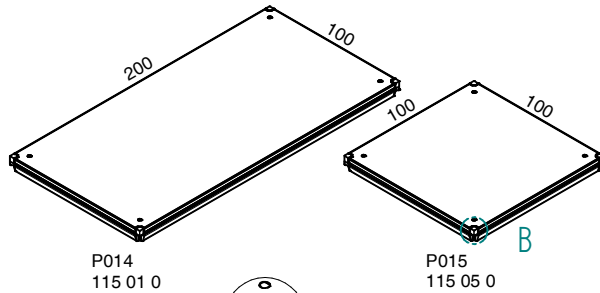

special shape circle

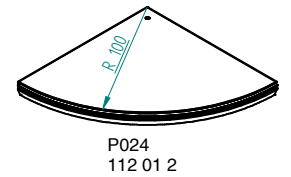

special shape triangel

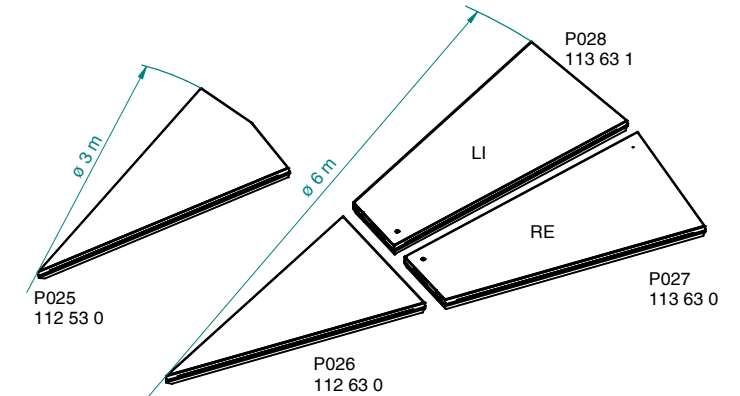
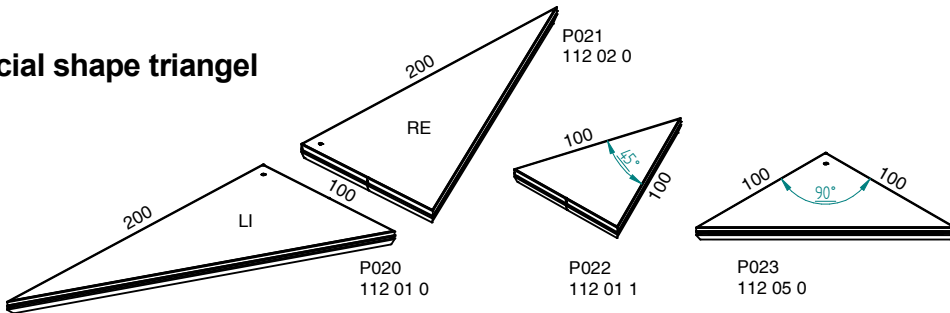

measurements in cm



6.1 P-platforms

special shape trapezoid

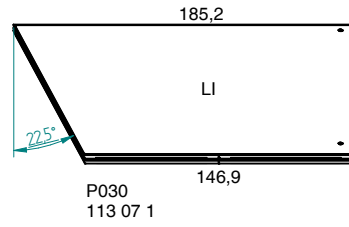
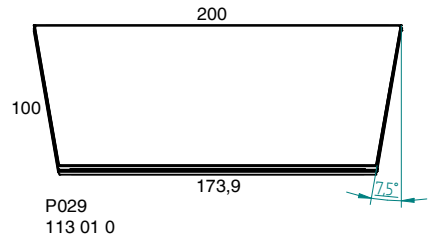

special surface

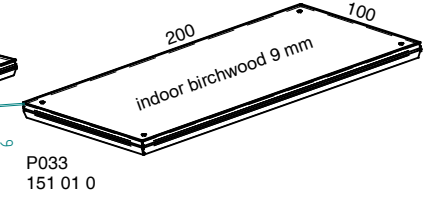
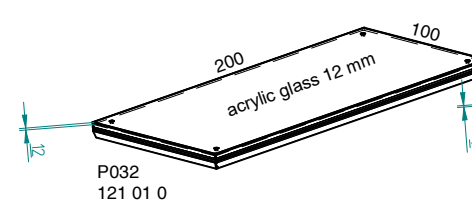

extras

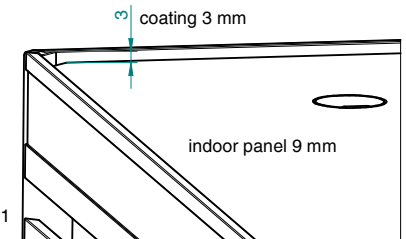
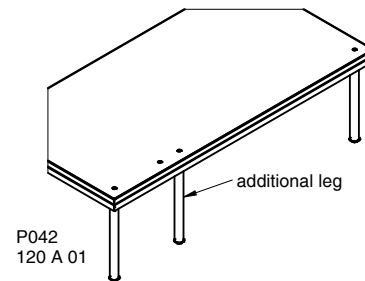
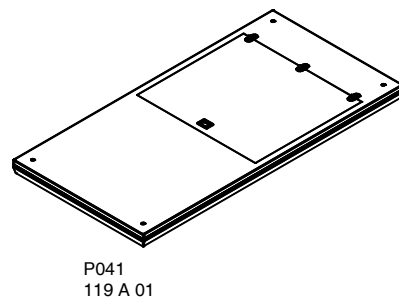
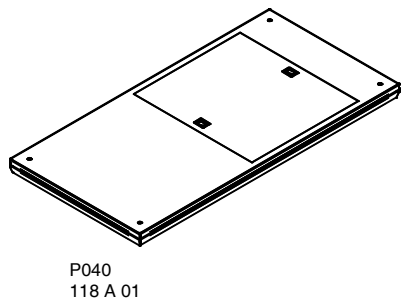
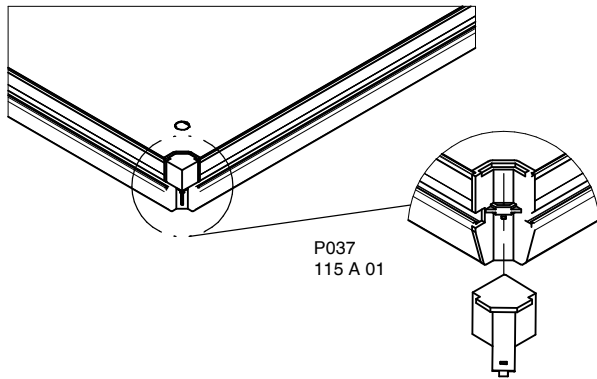
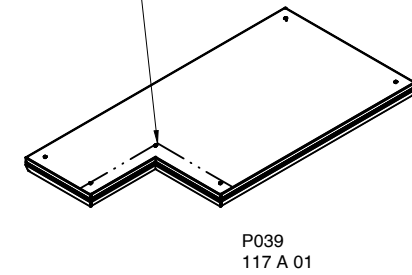
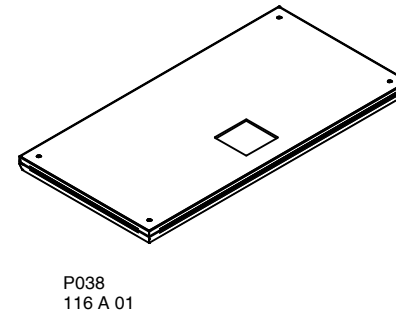
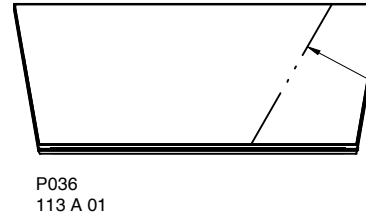
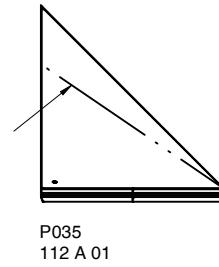
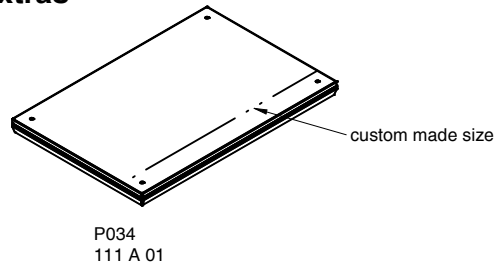

measurements in cm



6.1 P-platforms

Nr.: 6.1

edition: 02

page:2 / 2

standard execution, tier height 20 cm

fix LV

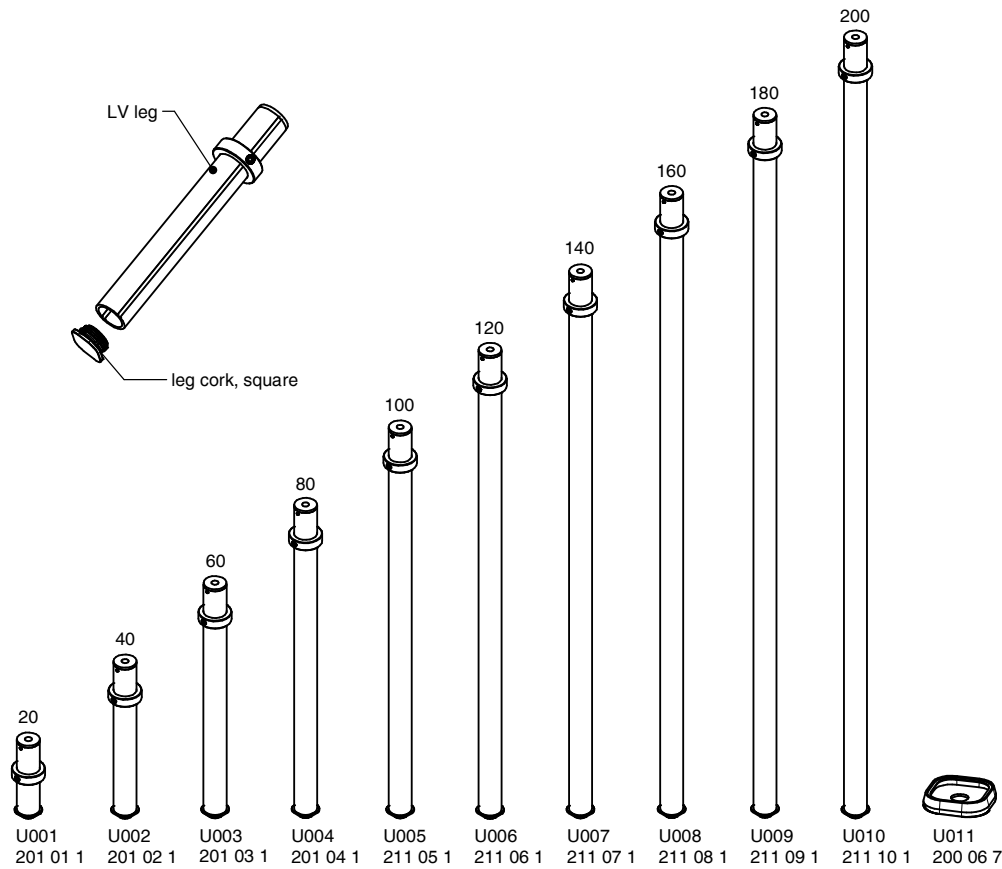

levelling VS

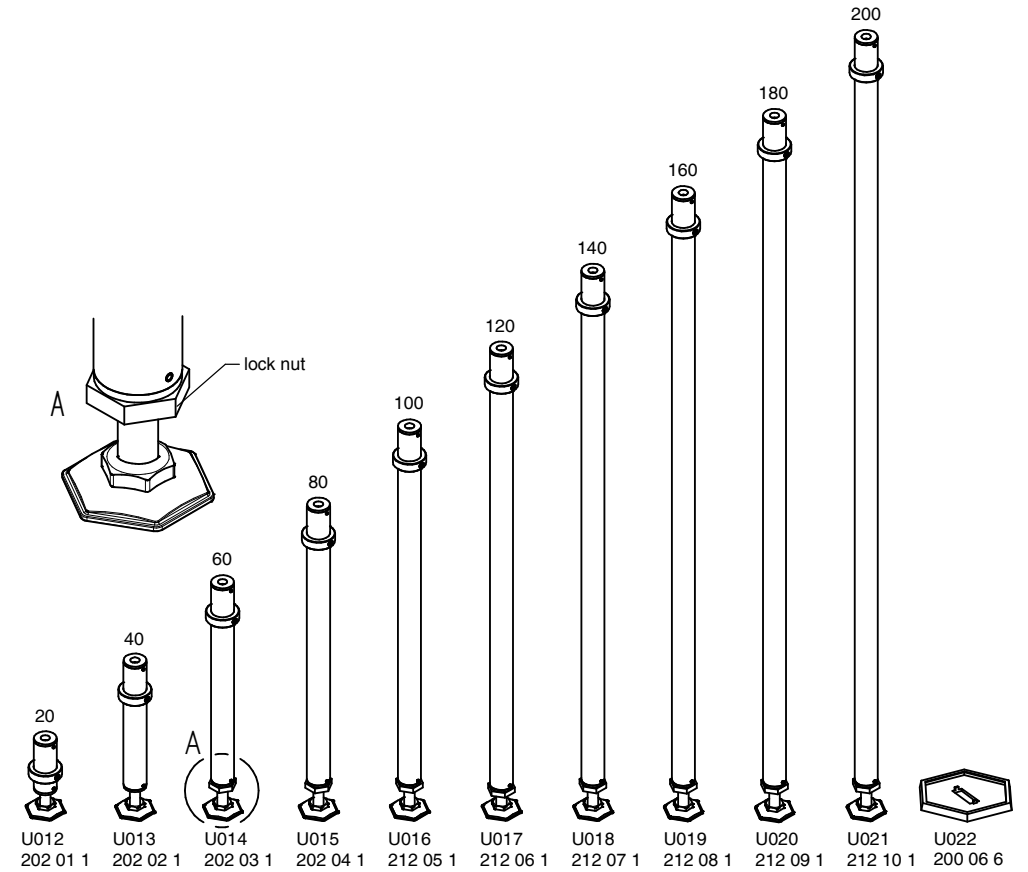

telescopic TF

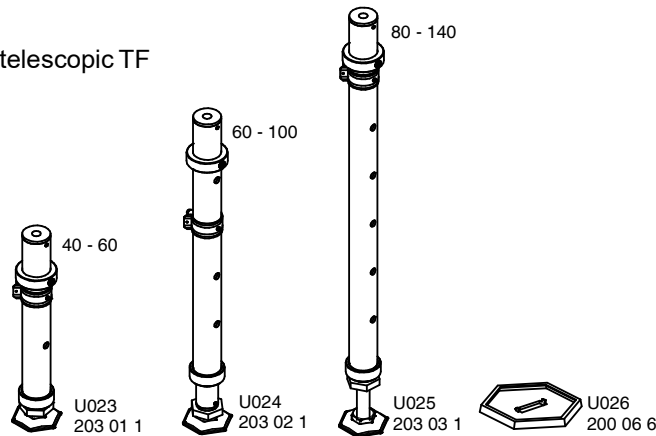

stepless adjustable LS in combination with nivtec LV leg

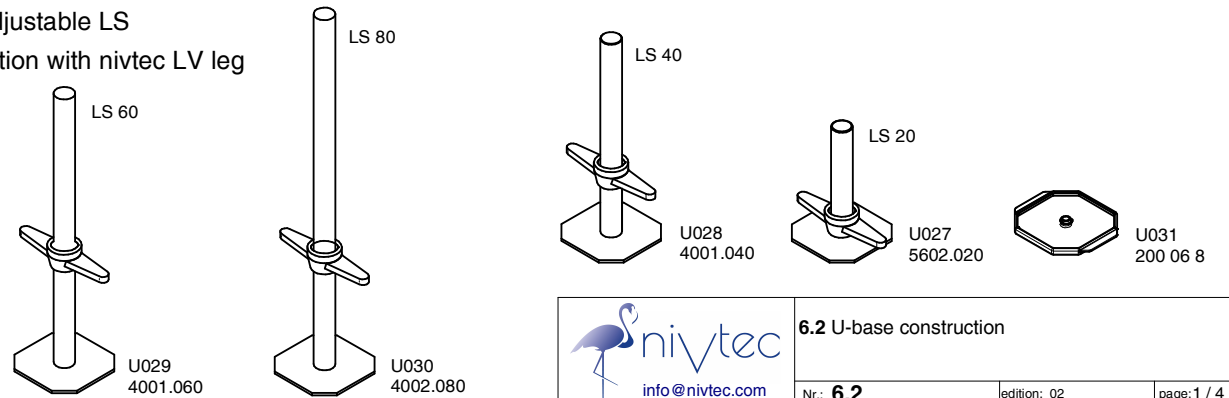

6.2 U-base construction

alu diagonal bracing

variant 1

wedge head / wedge head

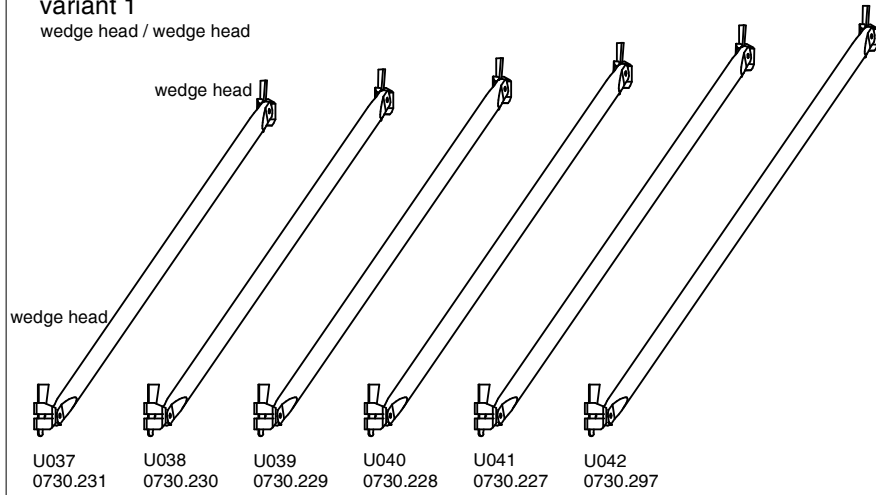

variant 3

semi coupler / semi coupler

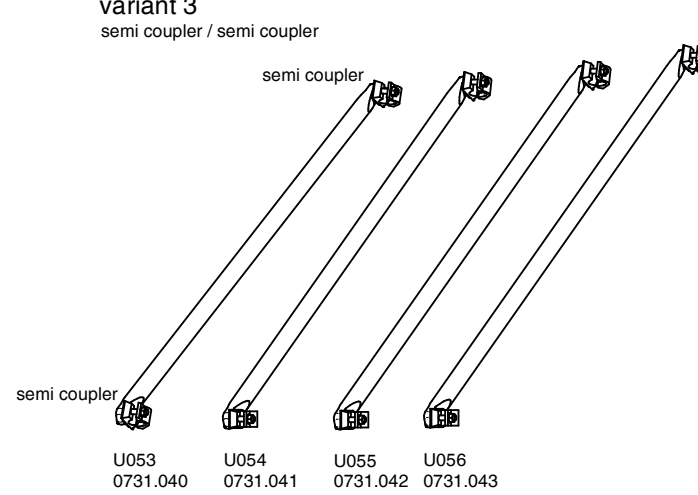

variant 2

wedge head / semi coupler

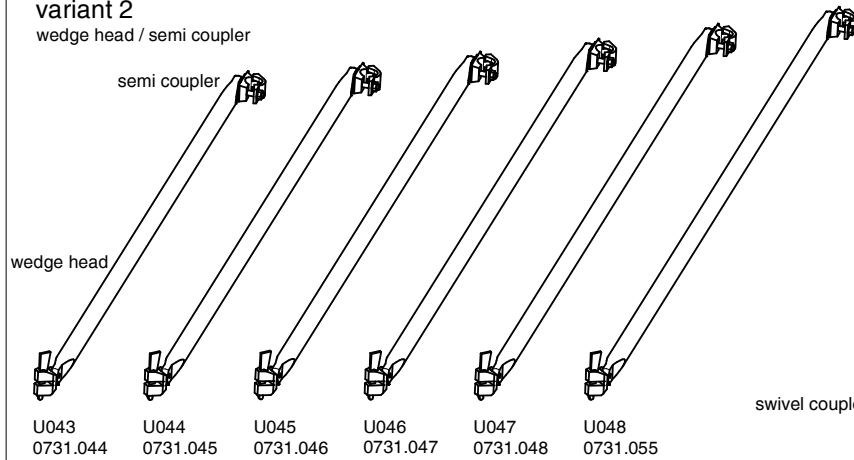

variant 4

swivel coupler / swivel coupler

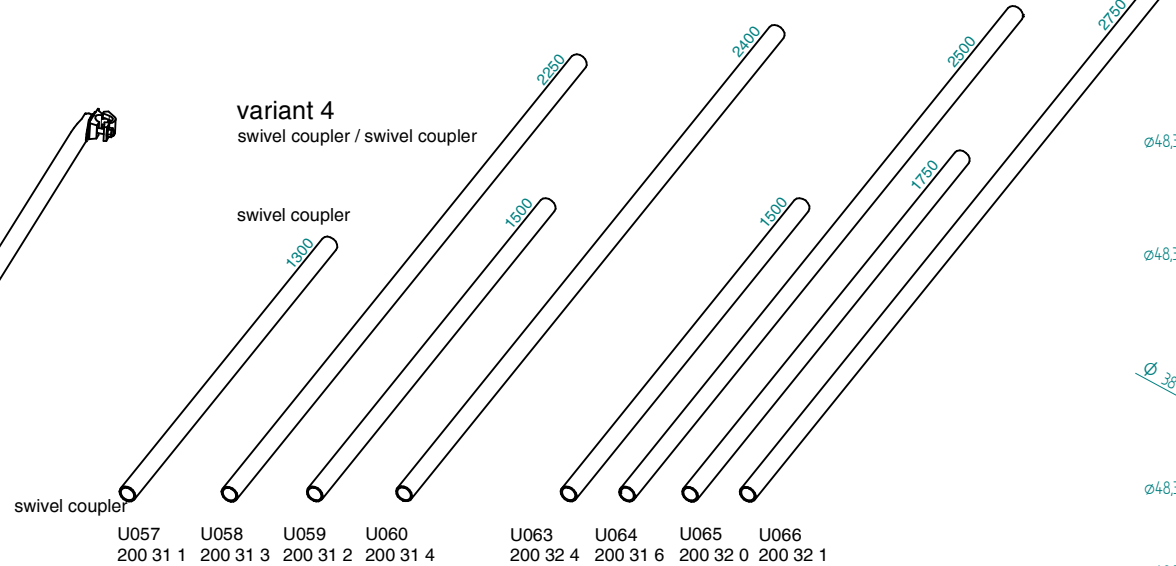

bracing accessories

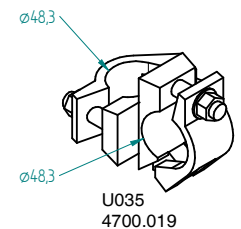
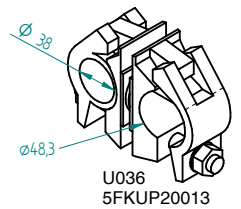
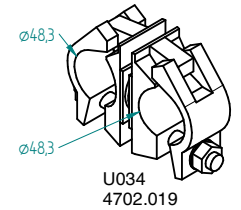
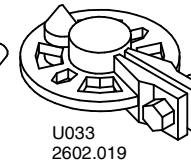
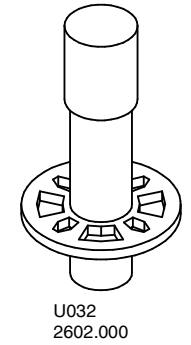

alu horizontal bracing

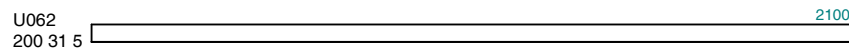
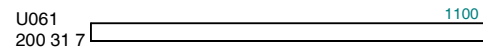
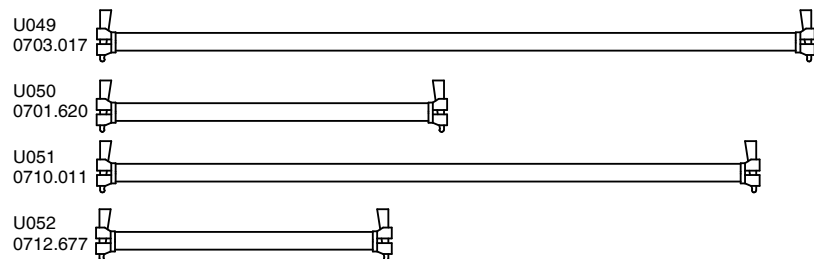

theatre tier height 16,66 cm

fix LV

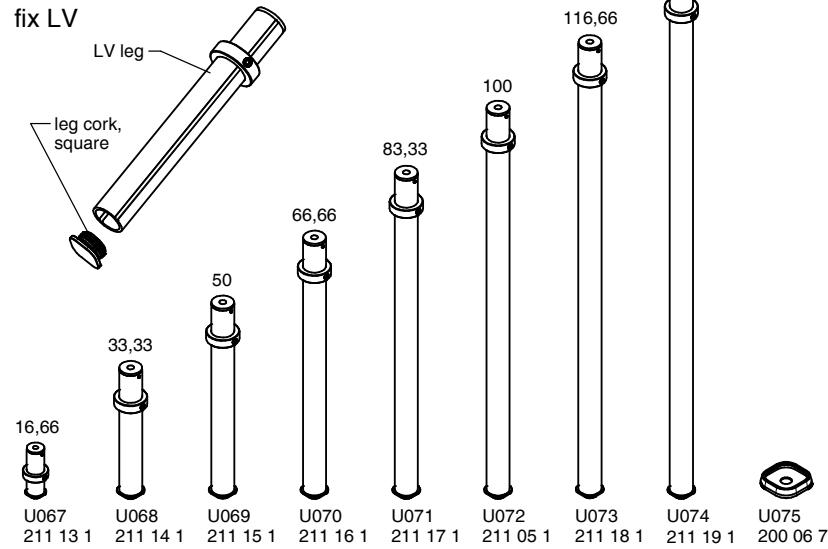

levelling VS

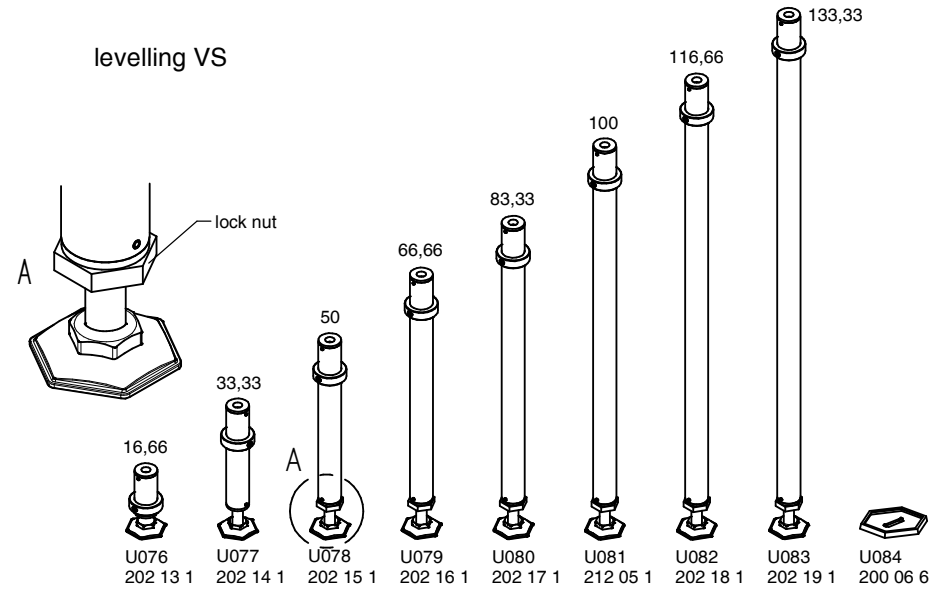

other

inclinable KG

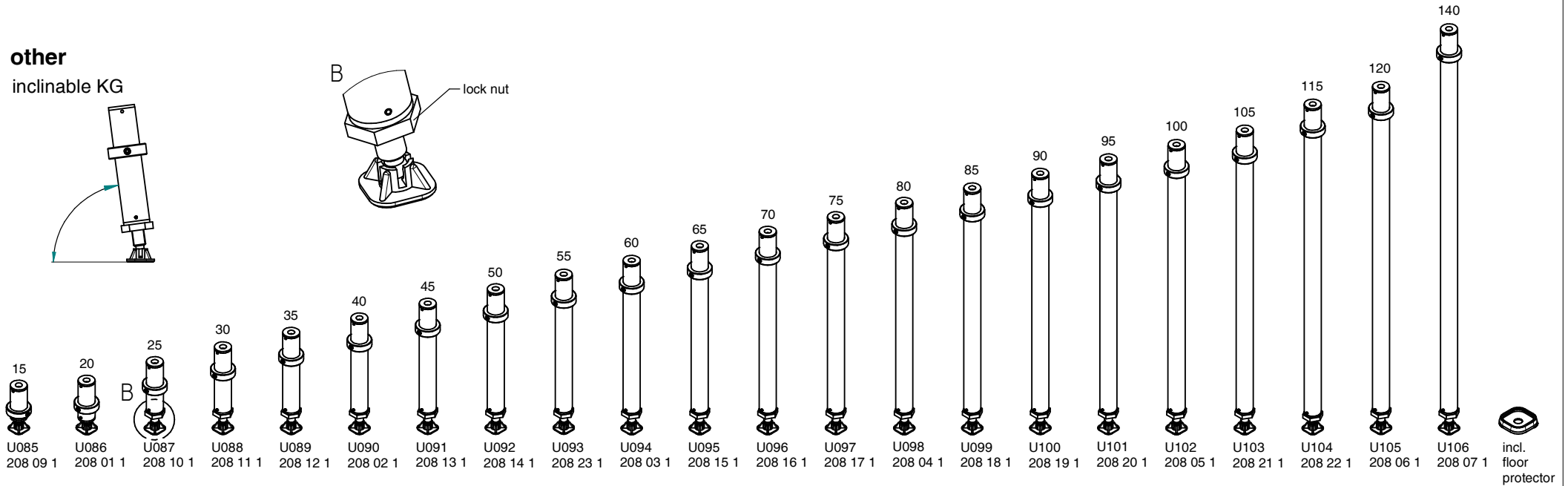

movable: wheels + extension adapters

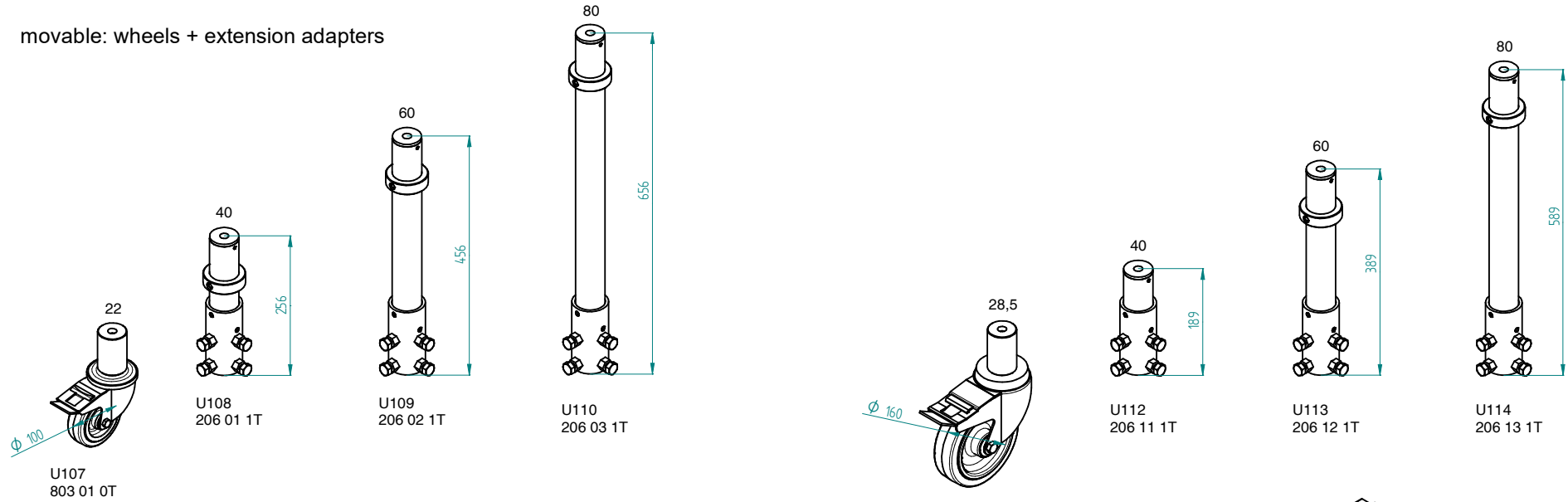

for scaffolding: weight girder

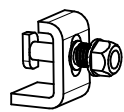
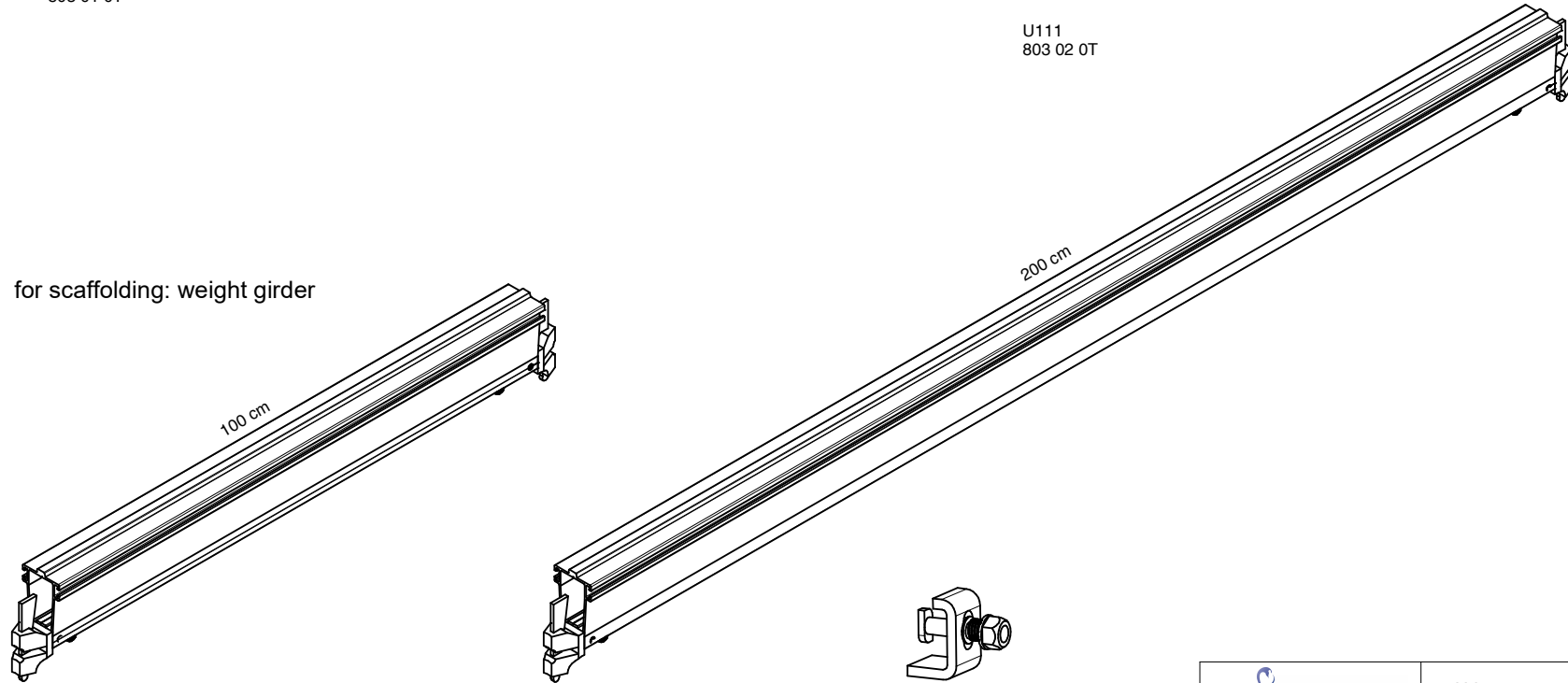

U115
207 01 0

U116
207 02 0

U117
207 05 0

stairway & gallery

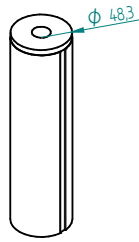

Z001
205 01 0

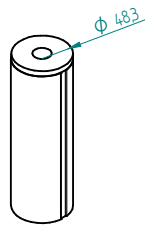

Z002
205 04 0

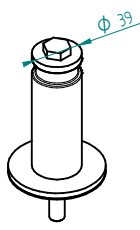

Z003
401 01 0

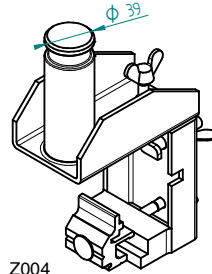

Z004
701 10 0

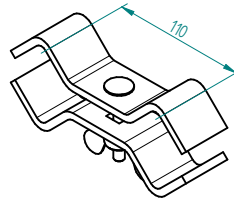

Z005
401 10 0

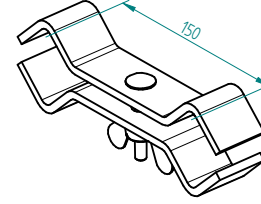

Z006
401 11 0

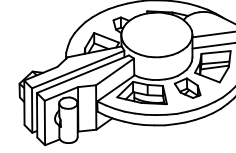

Z011
2602.019

leg distance 110 leg distance 150

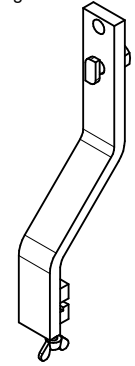

Z007
402 01 0

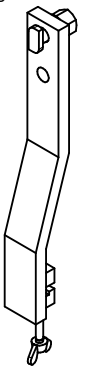

Z008
402 05 0

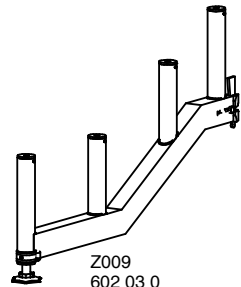

Z009
602 03 0
incl. accessories

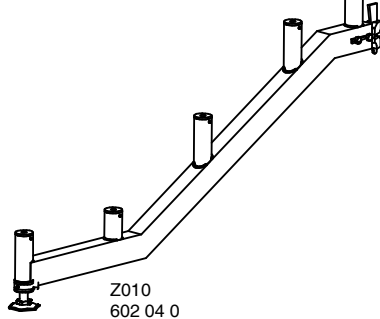

Z010
602 04 0
incl. accessories

ramp

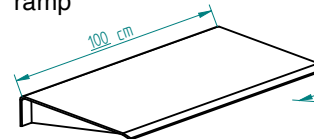

Z012
405 02 0

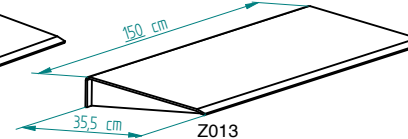

Z013
405 03 0

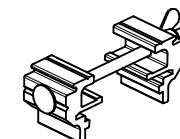

Z014
401 20 0

stage & gallery

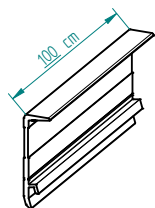

Z015
407 20 0

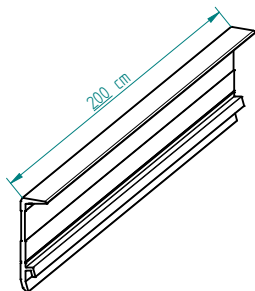

Z016
407 21 0

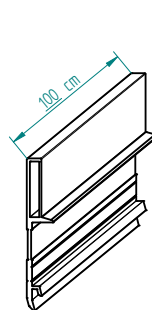

Z017
409 01 0

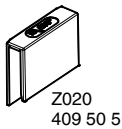

Z020
409 50 5

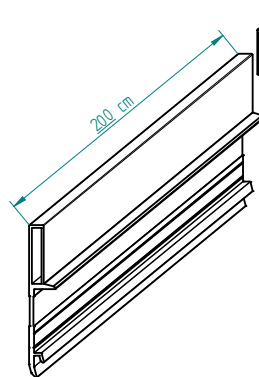

Z018
409 02 0



Z019
409 50 1

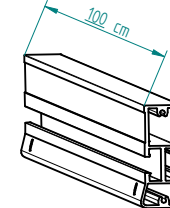

Z021
410 01 0



Z024
406 10 2
incl. accessories

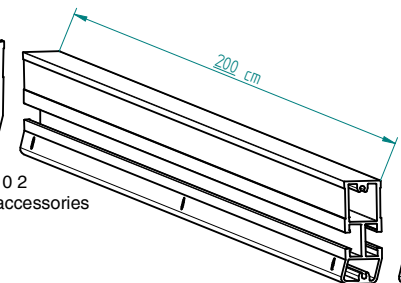

Z022
410 02 0



Z023
406 10 1
incl. accessories

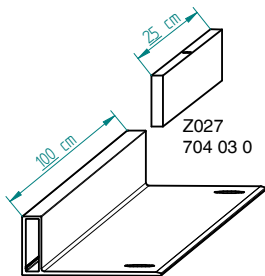

Z025 incl. accessories
705 01 0

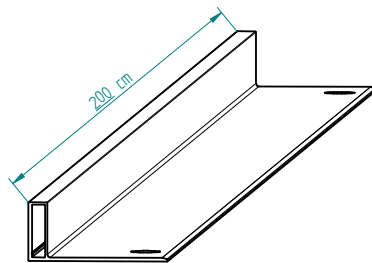

Z026 incl. accessories
705 02 0



Z028-Z035
502 01 0 - 500 00 1



Z036-Z037
505 01 0 - 505 25 0

other

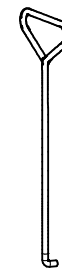

Z038
404 01 0



Z039
408 01 0

installation dimension: 245 x 245

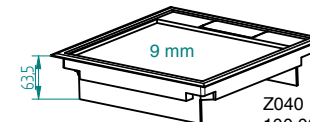

Z040
100 00 4

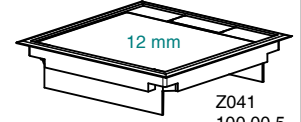

Z041
100 00 5



6.3 Z-accessories

connection of ascents and descents with stage

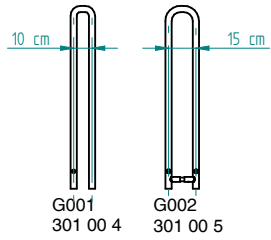

stage

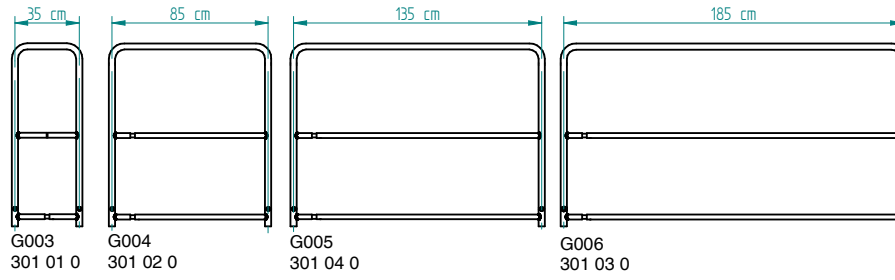

stage & gallery

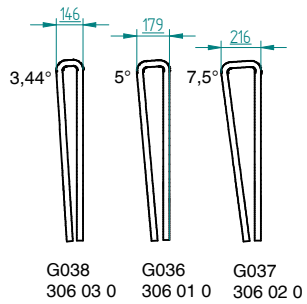
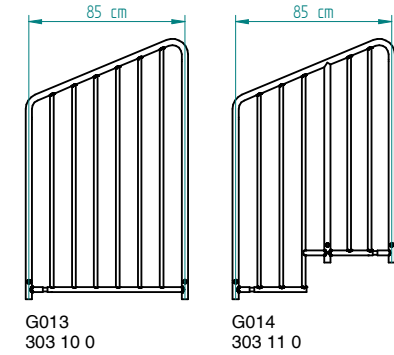
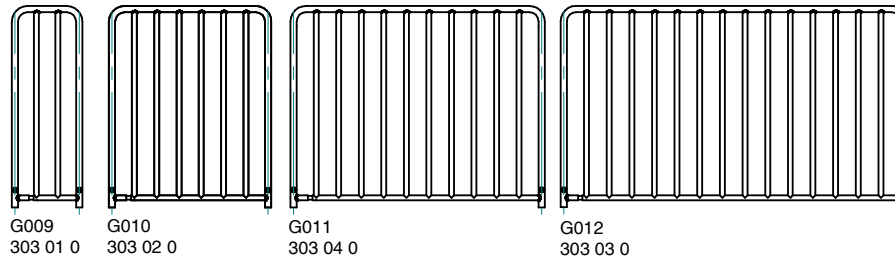

stairway: tier height 20 cm

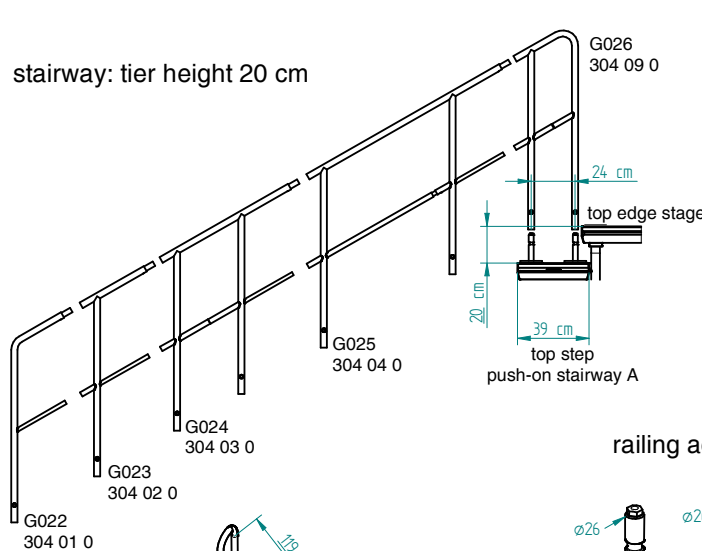

stairway: tier height 16,66 cm

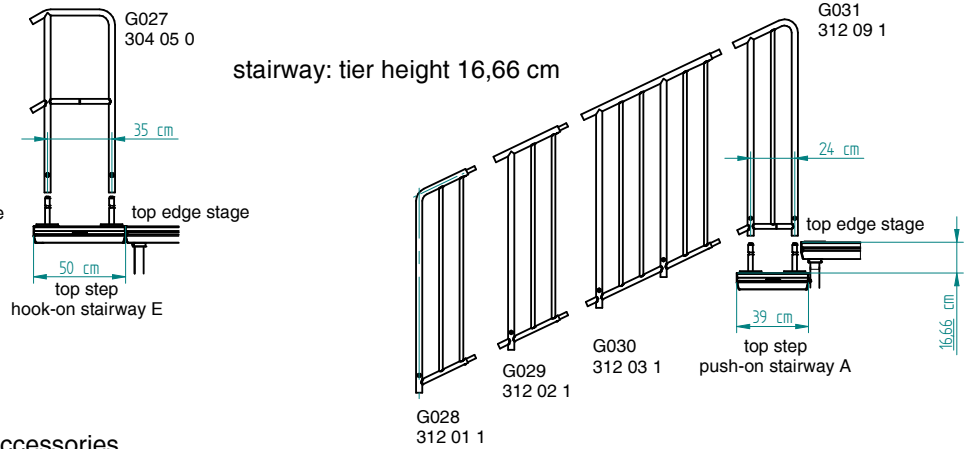

special rails & more

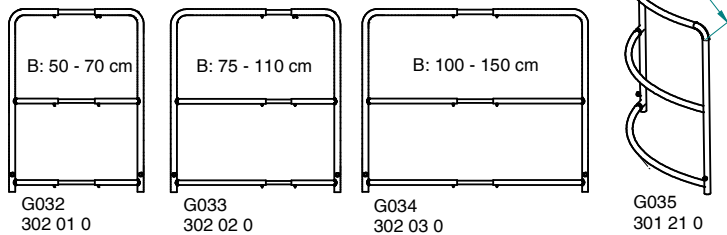

railing accessories

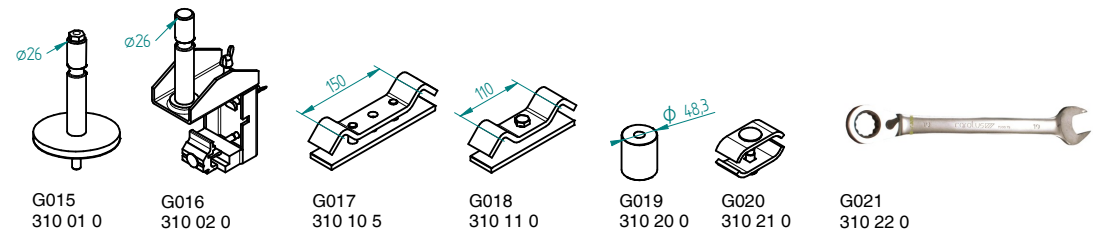

6.4 G-rails

safety

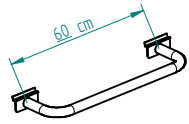

T001
801 01 0

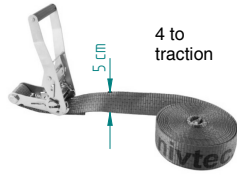

T002
802 01 1



T003
802 02 0

transport wheels

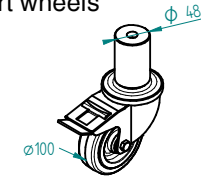

T004
803 01 0T

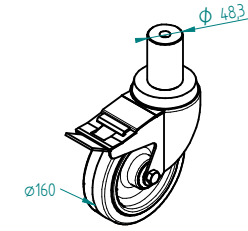

T005
803 02 0T

transport trolleys

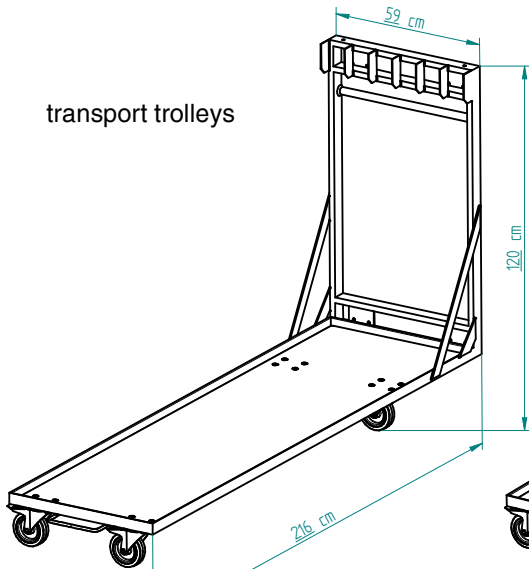

T006
805 01 0
incl. belt 1,6 to

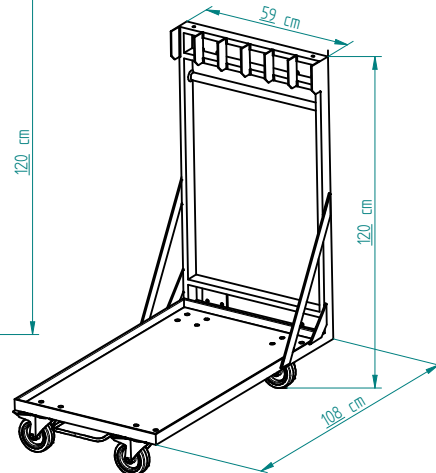

T007
805 02 0
incl. belt 1,6 to

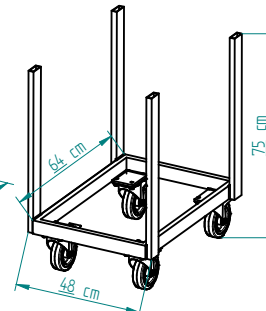

T008
804 01 0
incl. belt 1,6 to

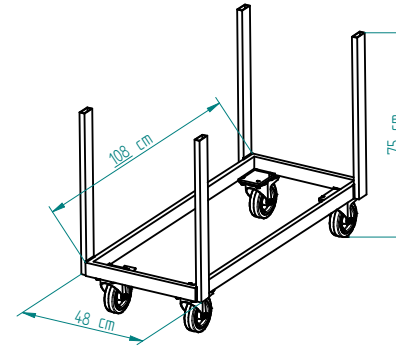

T009
804 02 0
incl. belt 1,6 to

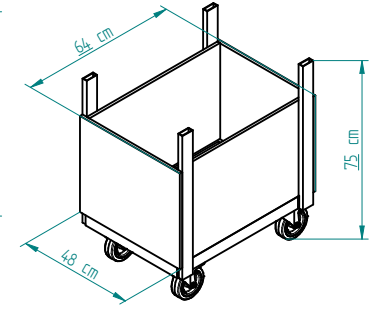

T010
804 03 0

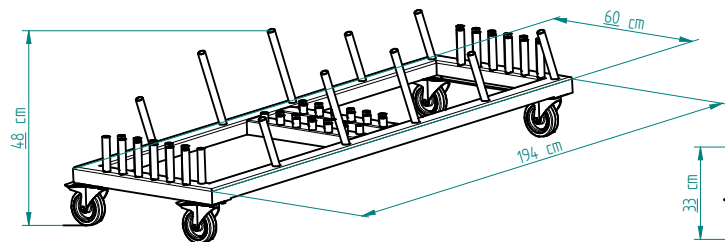

T011
806 01 0

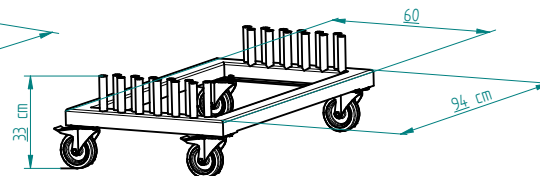

T012
806 02 0

platform

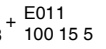
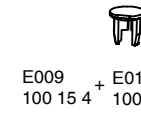
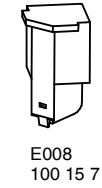
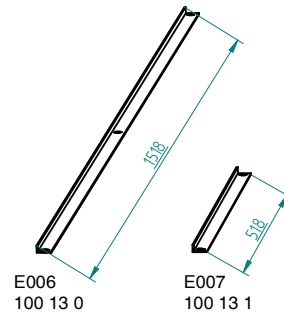
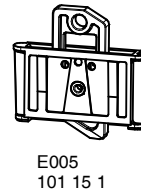
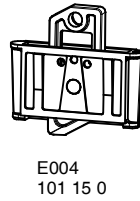
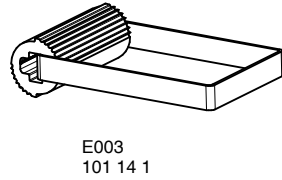
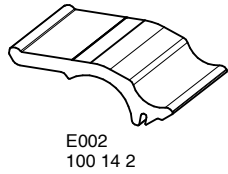

base construction

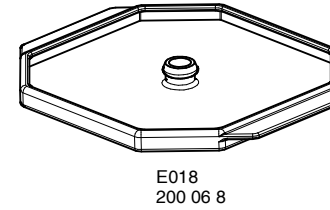
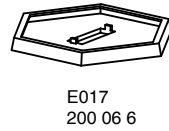

stairway

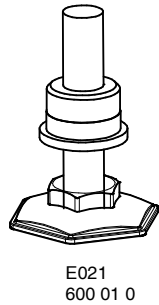

rail

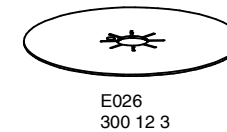
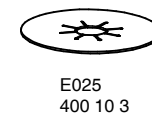
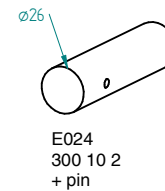
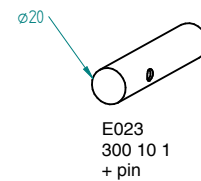

accessories & more

